



CEMENTING HEAD

PARVEEN cementing Head is used for cementing the annular space between casing and bore hole during 2nd stage of well construction cycle. The cementing head is employed to connect the pumps of the cementing trucks to the casing string and provides access for insertion of the cementing plugs.

PARVEEN's Cementing heads are available in sizes 4 1/2 " to 20", for working pressure of 2,000 to 10,000 psi. Cementing head sizes & working pressures are inversely related. Generally for smaller sizes more working pressure and for larger sizes less working pressure are the requirements. Cementing heads could be of single plug or double plug types. Caps are "Acme" threaded or quick lock type and fitted with swivel chain assembly. The double plug cementing head has three valve manifold and two plunger assembly. Cementing heads are manufactured from solid forged rounds of alloy steels AISI 4130/4140/ 4145 HEN-19 or equivalent material and are fully heat treated.

CEMENTING OPERATIONS

PARVEEN Cementing Head is suitable to carry out single stage as well as double stage cementing operation. It is provided with the following features:

- (a) Indicates when the top plug passes into the casing.
- (b) Simple in operation and provides easy loading of plugs.
- (c) Having manifold with lo-torque plug valve.
- (d) Provides continuous operation.
- (e) The plug container holds one or two plugs, the top plug and the bottom plug. The double plug container has a three in-torque valve manifold and two plunger assembly.
- (f) The length of plug containers are made to accommodate the standard length of plugs.
- (g) The cap is available with ACME thread and with lifting chain for lifting the plug container.
- (h) Adapters are available with all casing threads and buttress threads.
- (i) The standard adapters have a 6 inch Tong space with thread protectors.
- (j) The hammer unions used in manifolds are **PARVEEN's** make.

CEMENTING MANIFOLDS

Cementing manifolds are supplied with cementing heads or alone as per customer preference. It is an assembly of unions, plug valves, tee, nipples etc. These can be supplied in any size up to pressure ratings of 10,000psi pressure.

DIMENSIONAL DATA FOR DOUBLE PLUG CEMENTING HEAD															
PART NO.	Casing SIZE O. D.	A ± 1/2 CAP O.D.	B ± 1/8 PLUG CENTER I.D.	C ± 3/8 PLUG INSERT O.D.	D ± 1/8 THROAT I.D.	E ± 1/8 NIPPLE I.D.	F ± 6.0 MADE UP LENGTH	G ± 1.5 DISTANCE BETWEEN PLUNGER	H ± 4.0 CLEARANCE ABOVE TOP PLUNGER	I ± 1/2 PLUNGER CLEARANCE	J ± 1/2 PLUNGER CLEARANCE	± 1.5 K	± 1.5 L	± 1.5 M	± 1.5 N
50511900	4.1/2	8.0	4.81	2.50	4.92	3.92	59.00	10.62	19.53	1.56	1.47	11.50	9.0	12.5	14.00
50509700	5.1/2	8.66	5.75	3.25	5.25	4.67	60.12	11.12	20.19	2.50	1.94	11.81	9.29	13.0	14.33
50509900	7	11.0	7.20	4.25	6.70	5.92	60.12	11.12	20.19	2.07	2.66	11.81	9.29	13.0	14.33
50511600	7.5/8	11.5	7.81	4.75	7.25	6.37	60.12	11.62	20.19	2.73	2.97	11.81	9.00	12.5	14.33
50511400	8.5/8	12.5	8.81	5.50	8.25	7.51	60.12	11.62	20.19	3.73	3.47	11.5	9.50	13.50	14.50
50510100	9.5/8	13.80	9.76	6.75	9.20	8.53	63.74	12.60	20.43	4.65	3.94	12.00	10.00	14.48	15.00
50511200	10.3/4	14.5	10.87	8.00	10.31	9.56	63.74	13.62	20.50	5.83	4.50	12.50	10.5	15.5	16.00
50511000	11.3/4	15.5	11.87	7.75	11.31	10.77	64.00	13.62	21.00	6.89	5.00	12.50	10.5	15.5	16.00
50510300	13.3/8	16.92	13.41	10.00	12.88	12.35	69.80	14.25	22.95	8.31	5.77	14.17	10.50	16.14	16.65
50510700	16	19.68	15.90	12.50	15.34	15.00	83.97	20.40	29.40	9.56	7.01	14.97	12.29	22.28	17.97
50510500	18.5/8	23.0	18.62	15.0	18.0	17.25	93.0	21.50	30.20	9.76	8.31	16.50	14.0	23.50	19.50
50510900	20	24.0	20.0	16.5	19.44	18.73	93.0	21.50	30.20	9.76	9.00	16.50	14.0	23.50	19.50

- NOTE:**
1. PARVEEN reserves right to alter the design data if required.
 2. All dimensions are in inches.
 3. For other sizes & for single plug cementing head sizes please contact PARVEEN.
 4. For Nomenclature refer diagram at next page.

CEMENTING HEAD

NO.	DESCRIPTION
1	BODY
2	CHAIN WITH SWIVEL ASSY
3	CAP
4	SEAL METAL SEAL
5	PLUNGER ASSY
6	INDICATOR ASSY
7	ADAPTOR
8	CEMENTING MANIFOLD

CEMENTING HEAD (DOUBLE PLUG) HORIZONTAL INLET

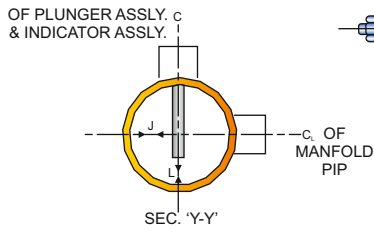
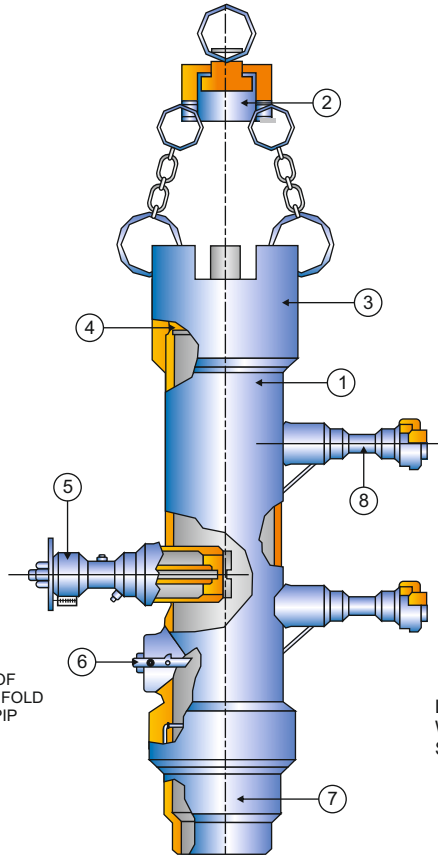

CEMENTING HEAD (SINGLE PLUG) HORIZONTAL INLET

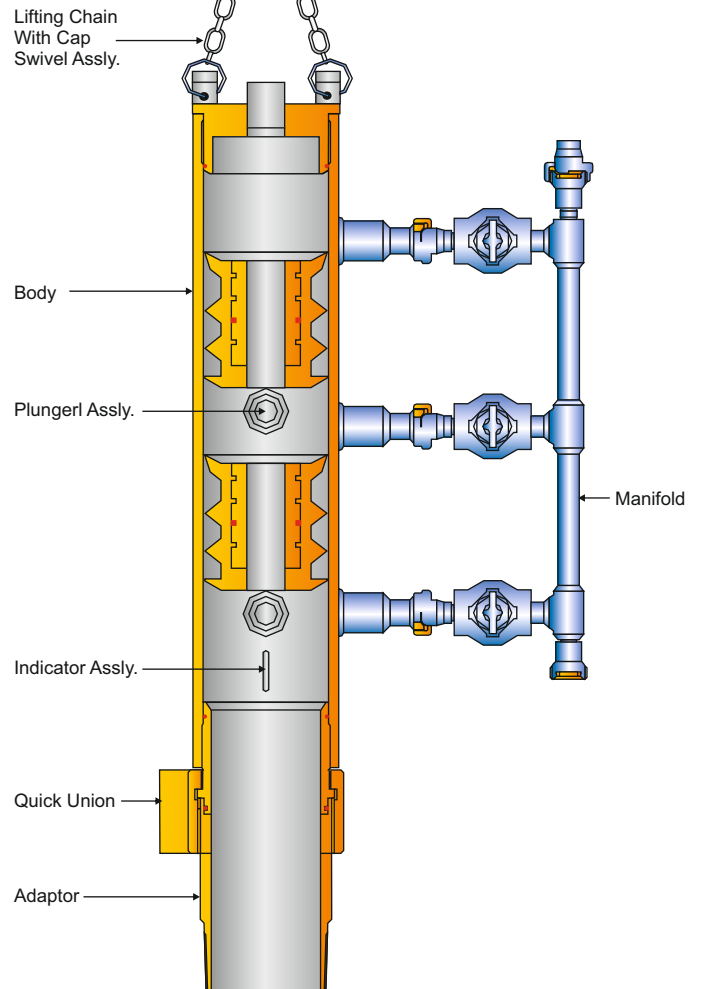
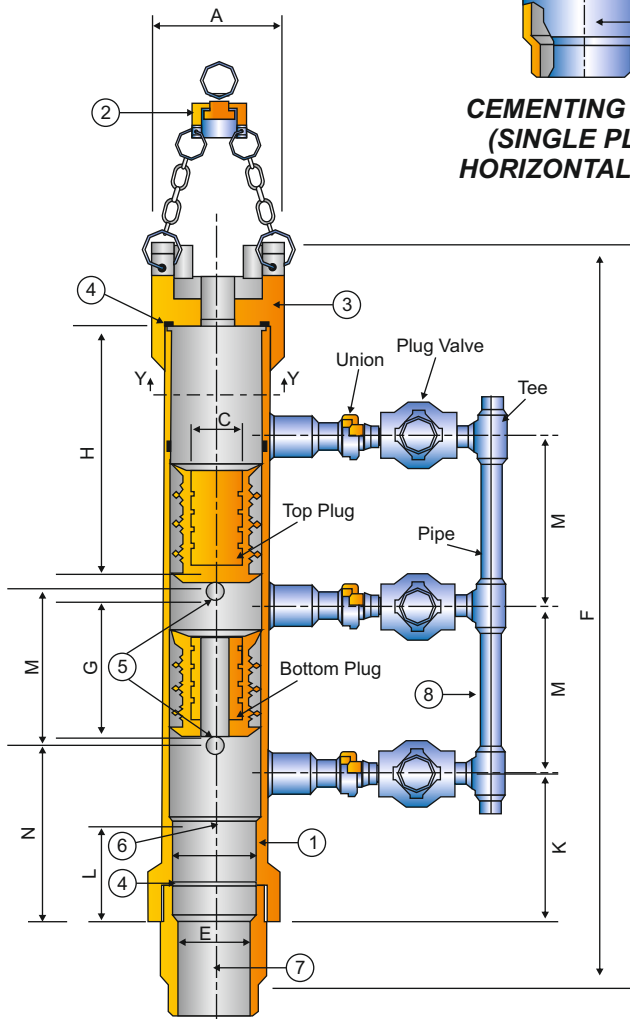

CEMENTING HEAD (DOUBLE PLUG) QUICK UNION TYPE