

CHECK VALVES

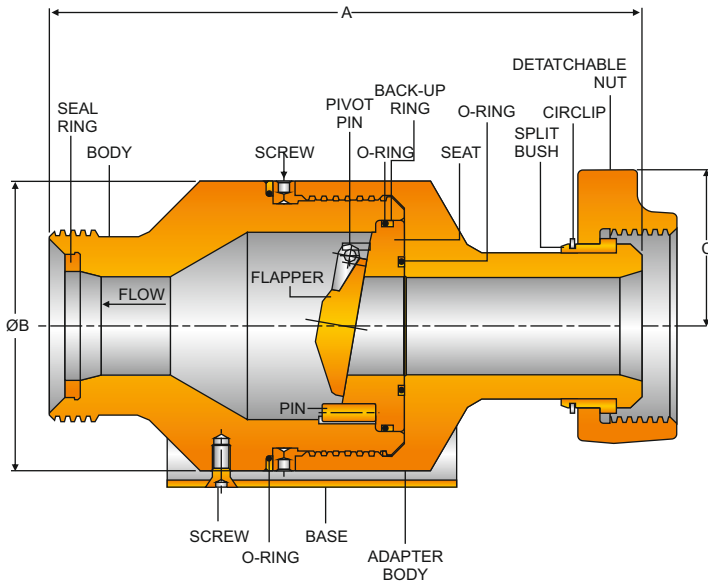

Flapper Type Check Valve (Reverse)

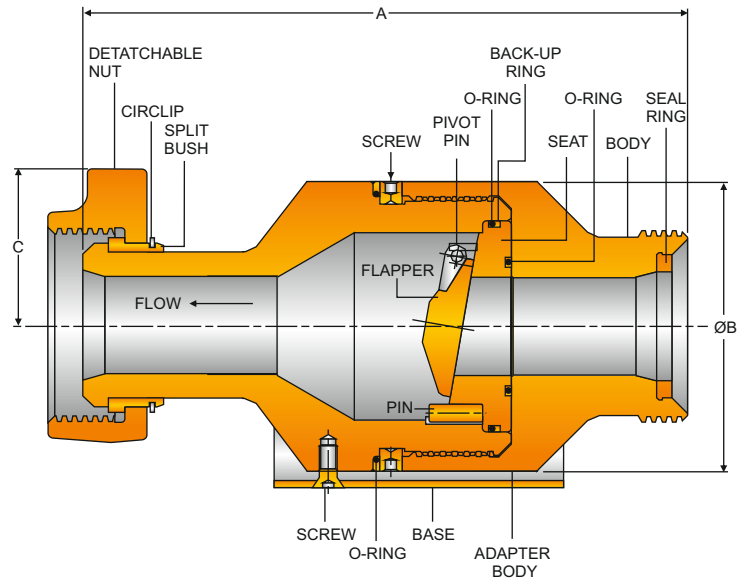

Flapper Type Check Valve (Standard)

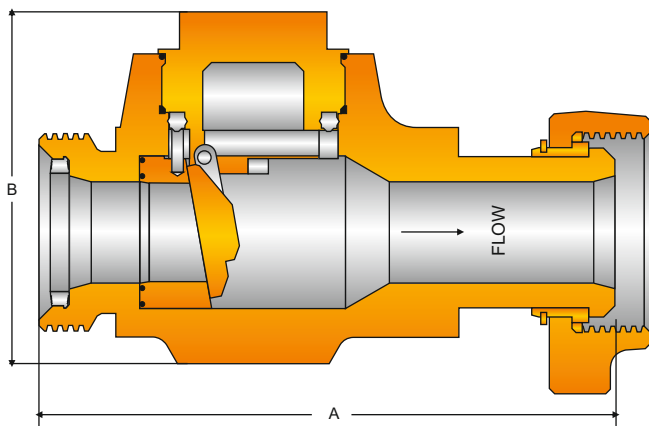

Top Entry Check Valve

Flapper Type Check Valve					
NOMINAL SIZE	A (INCH)	ØB (INCH)	C (INCH)	WEIGHT(LBSF)	
				STANDARD	REVERSE
2" x Fig. 1502 (MxF)	10.1	7.0	3.8	88	88
3" x Fig. 1502 (MxF)	15.6	8.1	4.4	121	121
4" x Fig. 1502 (MxF)	22.7	12.2	-	385	385

Top Entry Check Valve			
NOMINAL SIZE	A (INCH)	B (INCH)	WEIGHT (LBS)
3" x Fig. 1502 (MxF)	15.66	9.60	115
4" x Fig. 1502 (MxF)	19.76	12.00	275

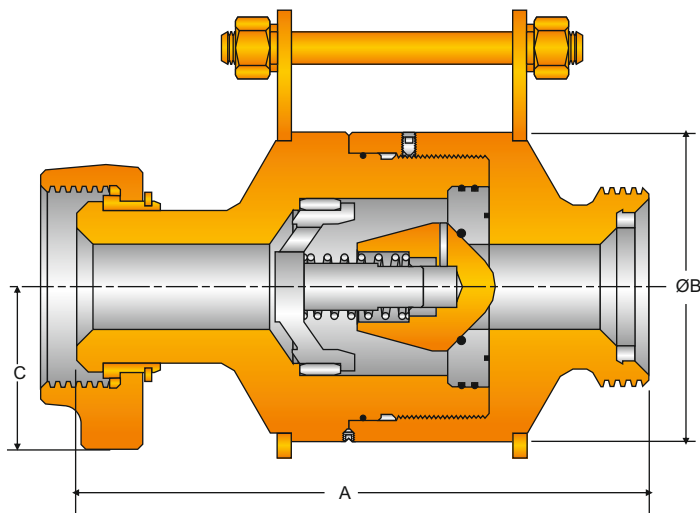

Dart Type Check Valve

Dart Type Check Valve				
NOMINAL SIZE	A (INCH)	ØB (INCH)	C (INCH)	WEIGHT (in LBS)
2" x Fig. 1502 (MxF)	14.0	6.9	3.74	112.5
3" x Fig. 1502 (MxF)	15.4	8.3	4.5	144.8