

SHORT SWEEP SWIVEL JOINT (BASIC DIMENSIONS) STYLE-30

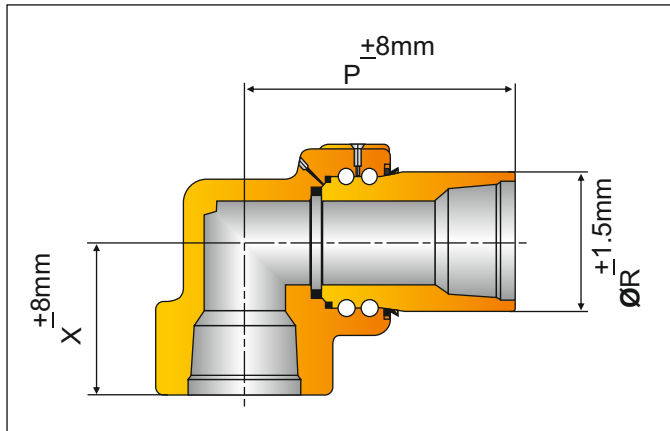

STYLE - 30 SHORT SWEEP SWIVEL JOINT

END CONNECTION = LP THREAD

MODEL:- PSSSJ - 30T

SIZE	P (MM)	P (INCH)	ØQ (MM)	ØQ (INCH)	R (MM)	R (INCH)	WT. (LBSF)	WT. (KGF)
1"	118	4.65	72	2.83	49	1.92	5.80	2.63
1 1/2"	121	4.76	75	2.95	61	2.40	7.82	3.55
2"	150	5.90	98	3.86	78	3.07	18.0	8.15
2 1/2"	182	7.16	120	4.72	90	3.54	24.80	11.25
3"	220	8.66	128	5.04	108	4.25	46.84	21.25
4"	252	9.92	158	6.22	132	5.19	64.81	29.4

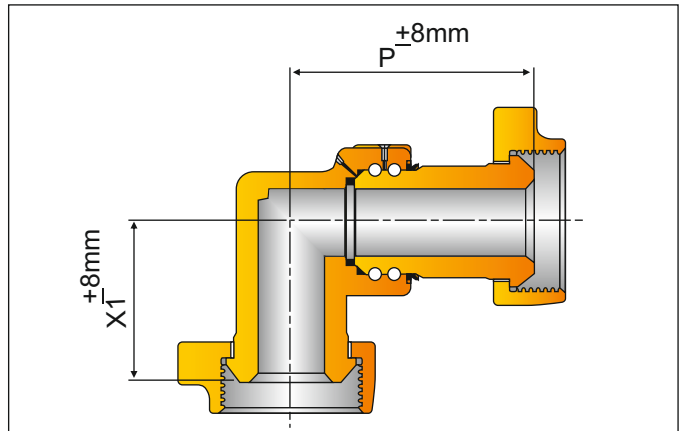

STYLE - 30 SHORT SWEEP SWIVEL JOINT

END CONNECTION = UNION (M X M) FIG.602/1002/1502

MODEL:- PSSSJ - 30MM

SIZE	P (MM)	P (INCH)	X1 (MM)	X1 (INCH)	WT. (LBSF)	WT. (KGF)
1"	118	4.65	153	6.02	10.7	4.85
1 1/2"	121	4.76	165	6.50	17.64	8.00
2"	150	5.90	198	7.80	37.14	16.85
2 1/2"	182	7.16	233	9.17	46.74	21.20
3"	220	8.66	271	10.67	68.68	31.15
4"	252	9.92	306	12.05	104.38	47.35

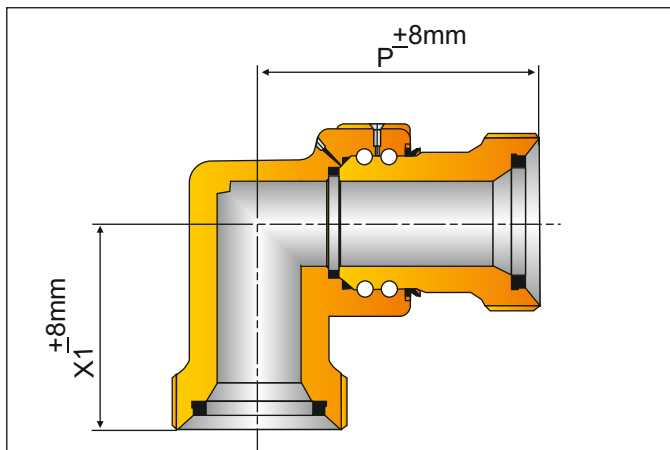

STYLE - 30 SHORT SWEEP SWIVEL JOINT

END CONNECTION = UNION (F X F) FIG.602/1002/1502

MODEL:- PSSSJ - 30FF

SIZE	P (MM)	P (INCH)	X1 (MM)	X1 (INCH)	WT. (LBSF)	WT. (KGF)
1"	118	4.65	153	6.02	9.20	4.17
1 1/2"	121	4.76	165	6.50	10.50	4.75
2"	150	5.90	198	7.80	23.14	10.5
2 1/2"	182	7.16	233	9.17	40.78	18.5
3"	220	8.66	271	10.67	60.62	27.5
4"	252	9.92	306	12.05	90.16	40.9

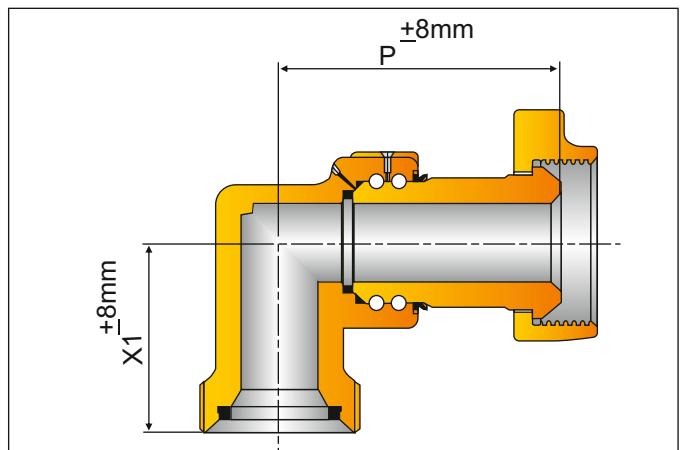

STYLE - 30 SHORT SWEEP SWIVEL JOINT

END CONNECTION = UNION (M X F) FIG.602/1002/1502

MODEL:- PSSSJ - 30MF

SIZE	P (MM)	P (INCH)	X1 (MM)	X1 (INCH)	WT. (LBSF)	WT. (KGF)
1"	118	4.65	153	6.02	10.6	4.8
1 1/2"	121	4.76	165	6.50	14.66	6.65
2"	150	5.90	198	7.80	31.41	14.25
2 1/2"	182	7.16	233	9.17	45.63	20.70
3"	220	8.66	271	10.67	66.58	30.20
4"	252	9.92	306	12.05	100.00	45.20