

SHORT SWEEP SWIVEL JOINT (BASIC DIMENSIONS) STYLE-50

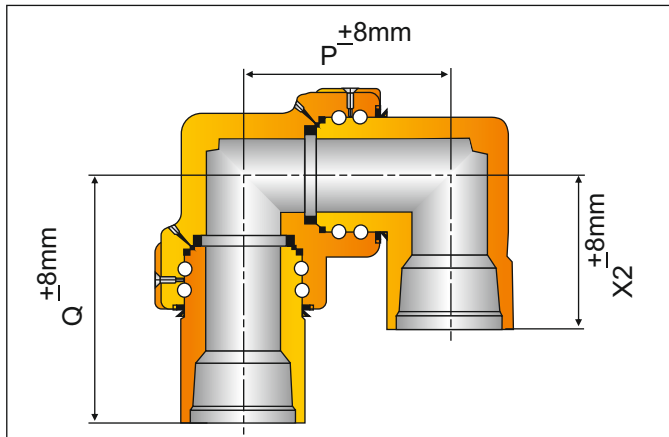

STYLE - 50 SHORT SWEEP SWIVEL JOINT

END CONNECTION = LP THREAD

MODEL:- PSSSJ - 50T

SIZE	P (MM)	P (INCH)	Q (MM)	Q (INCH)	R (MM)	R (INCH)	WT. (LBSF)	WT. (KGF)
1"	108	4.25	118	4.65	70	2.75	8.60	3.9
1 1/2"	110	4.33	121	4.75	90	3.54	12.90	5.85
2"	152	5.98	150	5.90	110	4.33	29.10	13.2
2 1/2"	195	7.67	182	7.16	130	5.11	39.68	18.0
3"	202	7.95	220	8.66	110	4.33	66.60	30.2
4"	260	10.23	252	9.22	130	5.11	98.0	44.4

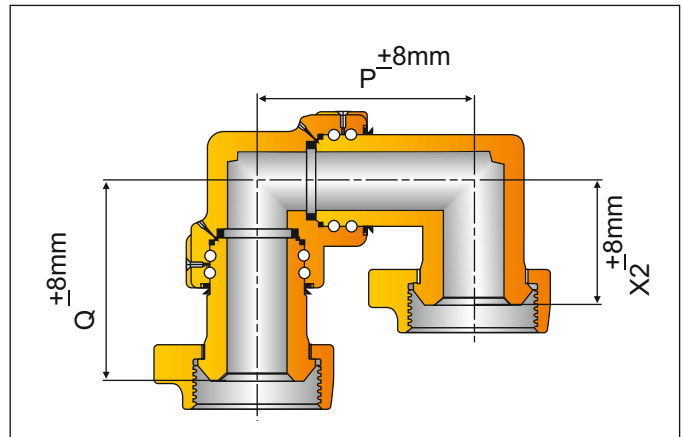

STYLE - 50 SHORT SWEEP SWIVEL JOINT

END CONNECTION = UNION (M X M) FIG.602/1002/1502

MODEL:- PSSSJ - 50MM

SIZE	P (MM)	P (INCH)	Q (MM)	Q (INCH)	X2 (MM)	X2 (INCH)	WT. (LBSF)	WT. (KGF)
1"	108	4.25	153	6.02	118	4.65	13.80	6.26
1 1/2"	110	4.33	165	6.50	121	4.75	23.46	10.60
2"	152	5.98	198	7.80	150	5.90	51.72	23.46
2 1/2"	195	7.67	233	9.17	182	7.16	60.30	27.35
3"	202	7.95	271	10.67	220	8.66	96.00	43.55
4"	260	10.23	306	12.05	252	9.92	140.65	63.80

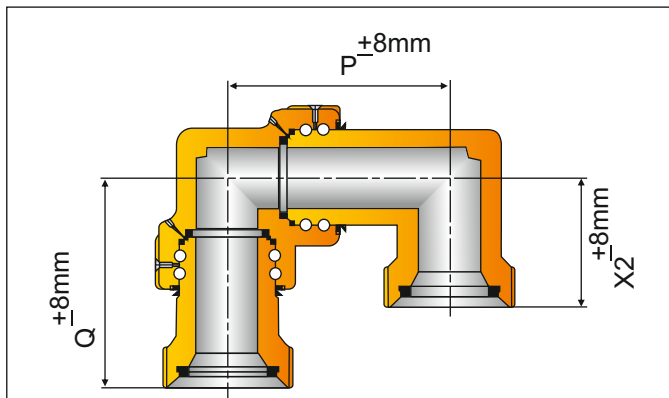

STYLE - 50 SHORT SWEEP SWIVEL JOINT

END CONNECTION = UNION (F X F) FIG.602/1002/1502

MODEL:- PSSSJ - 50FF

SIZE	P (MM)	P (INCH)	Q (MM)	Q (INCH)	X2 (MM)	X2 (INCH)	WT. (LBSF)	WT. (KGF)
1"	108	4.25	153	6.02	118	4.65	12.80	5.8
1 1/2"	110	4.33	165	6.50	121	4.75	18.0	8.15
2"	152	5.98	198	7.80	150	5.90	35.7	16.2
2 1/2"	195	7.67	233	9.17	182	7.16	51.2	23.25
3"	202	7.95	271	10.67	220	8.66	91.7	41.60
4"	260	10.23	306	12.05	252	9.92	128.70	58.38

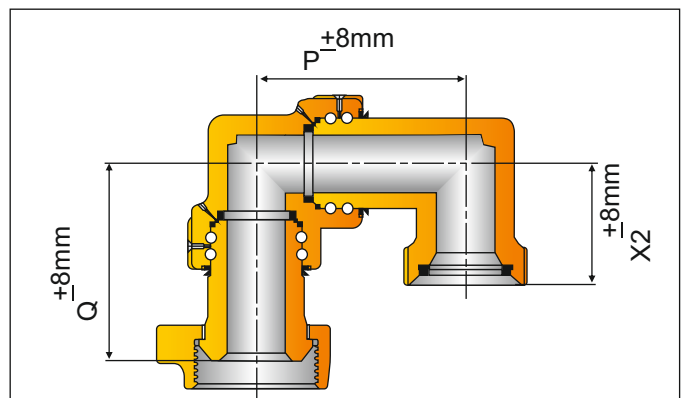

STYLE - 50 SHORT SWEEP SWIVEL JOINT

END CONNECTION = UNION (M X F) FIG.602/1002/1502

MODEL:- PSSSJ - 50MF

SIZE	P (MM)	P (INCH)	Q (MM)	Q (INCH)	X2 (MM)	X2 (INCH)	WT. (LBSF)	WT. (KGF)
1"	108	4.25	153	6.02	118	4.65	13.22	6.0
1 1/2"	110	4.33	165	6.50	121	4.75	22.40	10.0
2"	152	5.98	198	7.80	150	5.90	44.10	20.0
2 1/2"	195	7.67	233	9.17	182	7.16	56.43	25.6
3"	202	7.95	271	10.67	220	8.66	97.44	44.2
4"	260	10.23	306	12.05	252	9.92	138.11	62.65