

TUBING HANGER SPOOL & COUPLING

PARVEEN also manufactures **Tubing Hanger Spools** and **Tubing Hanger Couplings**. Tubing Hanger Spool is used in combination with Tubing Hanger coupling, Wrap around tubing hanger (PTHSW) and 'PTHS' type tubing spool. Tubing Hanger Coupling allows installation by screwing the union nut of the tubing hanger coupling without a need to turn the X-mas tree. Coupling is threaded for installing a back pressure valve. Top & Bottom of the coupling can be threaded to suit customer's requirement.

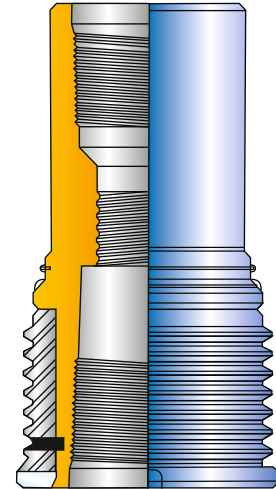

Tubing Hanger Coupling

SPECIFICATIONS OF TUBING HANGER COUPLING			
Size			
4 1/2 x 2 3/8	API	UPSET	TUBING
4 1/2 x 2 7/8	API	UPSET	TUBING
6 5/16 x 3 1/2	API	UPSET	TUBING
6 7/8 x 4 1/2	API	UPSET	TUBING

SPECIFICATIONS OF TUBING HANGER SPOOL		
Bottom Flange x Studded Top Flange	Bore	Bottom Prep
7 1/16 2000 x 2 9/16 2000	2 9/16	4 1/2
7 1/16 3000 x 2 1/16 5000	2 1/16	4 1/2
7 1/16 3000 x 2 9/16 5000	2 9/16	4 1/2
7 1/16 5000 x 2 1/16 5000	2 1/16	4 1/2
7 1/16 5000 x 2 9/16 5000	2 9/16	4 1/2
7 1/16 5000 x 3 1/8 5000	3 1/8	6 5/16
7 1/16 5000 x 4 1/16 5000	4 1/8	6 7/8
9 5000 x 2 1/16 5000	2 1/16	4 1/2
9 5000 x 3 1/8 5000	3 1/8	6 5/16
9 5000 x 4 1/16 5000	4 1/8	6 7/8
11 5000 x 2 9/16 5000	2 9/16	4 1/2
7 1/16 10000 x 2 1/16 10000	2 1/16	4 1/2
7 1/16 10000 x 2 9/16 10000	2 9/16	4 1/2
7 1/16 10000 x 3 1/16 10000	3 1/16	6 5/16
9 10000 x 4 1/16 10000	4 1/16	6 7/8
7 1/16 15000 x 1 13/16 15000	1 13/16	4 1/2
7 1/16 15000 x 2 1/16 15000	2 1/16	4 1/2
7 1/16 15000 x 2 9/16 15000	2 9/16	4 1/2

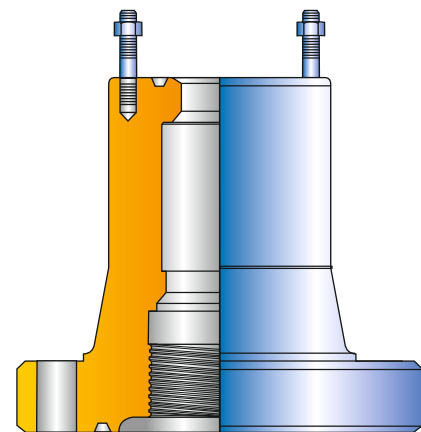

Tubing Hanger Spool

NOTE :

All dimensions are in inches