

2-1/8" OD MULTI-STAGE SETTING TOOL

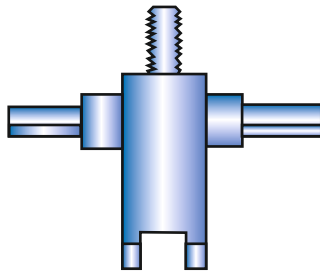

**Bleeder Wrench
WST-2125-146**

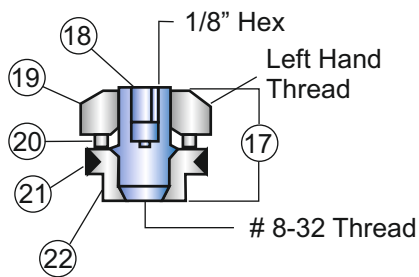

**Bleeder Valve Assy.
WST-2125-142**

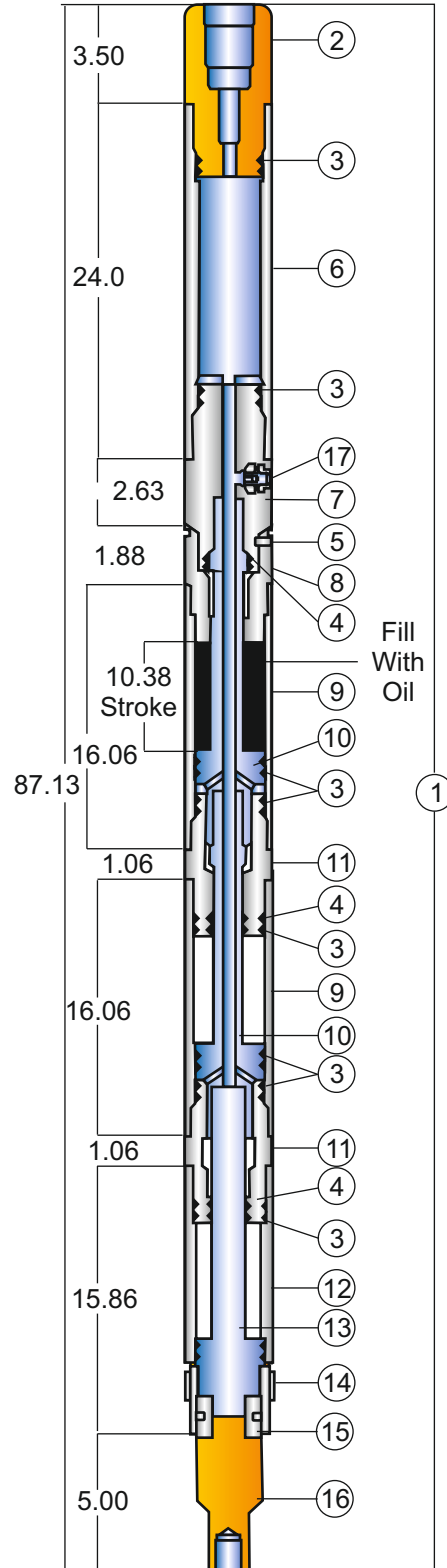



2-1/8" OD MULTI-STAGE SETTING TOOL

Parts List

Item	Part Number	Req	Description
1	WST-2125-001		Assy. - 2-1/8" O.D. "Multi-Stage Setting Tool, Top Connection to Fit "GO" 1-7/16" O.D. High Pressure Firing Head- Incl. Items 2-17
2	WST-2125-020	1	Top Sub
3*	000-N569-222	18	O- Ring- 90 Duro
4*	000-N569-212	6	O- Ring- 90 Duro
5*	052-5304-003	1	Brass Shear Screw - Approx. 2300 Lbs Shear
6	WST-5304-121	1	Power Chamber
7*	WST-2125-122	1	Shear Sub - Ported For Bleeder Valve
	WST-2125-132		Shear Sub - Unported (not Bleeder Valve)
8	WST-2125-123	1	Orifice Sub
9	WST-2125-124	2	Top Cylinder
10	WST-2125-125	2	Top Piston
11	WST-2125-126	2	Connector Sub
12	WST-2125-127	1	Bottom Cylinder
13	WST-2125-128	1	Bottom Piston
14	WST-2125-029	1	Lock Ring
15	WST-2125-030	1	Safety Release Nut- 52,000 Lbs. Weak Point
16	WST-2125-131	1	Bottom Adapter
17	WST-2125-142	1	Assy. - Bleeder Valve - Items 18-22
18	WST-2125-143	1	Stem
19	WST-2125-144	1	Retainer Nut
20	WST-2125-145	1	Seat
21*	000-N569-111	1	O- Ring - 90 Duro
22*	000-N569-006	1	O- Ring - 90 Duro
23	WST-2125-146		Bleeder Wrench
*	WST-2125-110		O- Ring Kit -0 325° - For WST-2125-110 Incl. Items 3,4,5,21,22-

Tool total stroke: 10.36 in.
 Tool piston area: 3.6 in.²
 Tool max. Pull: 30,000 lbs. At 6.91 inch stroke
 Unported tool max. Hydrostatic pressure: 15,000 psi
 Ported tool max. Hydrostatic pressure: 10,000 psi