

## DRILL COLLARS

### PERMEABILITY

Relative Magnetic permeability shall be less than 1.010 through the entire length and the level of such permeability to be uniform. This level of permeability remains stable despite fluctuation of local plastic deformation and temperature fluctuation during operation.

### SIZES

Size conform to API Spec. 7.

### CORROSION RESISTANCE

Austenitic stainless steel drill collars are subject to cracking due to conjoint action of tensile stress and certain specific corrodents. This is called stress corrosion cracking.

Resistance to Corrosion can be demonstrated by subjecting materials from each Drill Collar to the corrosion test as specified in ASTM A262 practice.

### ULTRASONIC TESTING

Drill collar bodies are inspected ultrasonically full length over the circumference of the body before boring. Examination Techniques are specified in ASTM E 114 (direct contact method) and ASTM E 214 and / or ASTM E 1001 (immersion method).

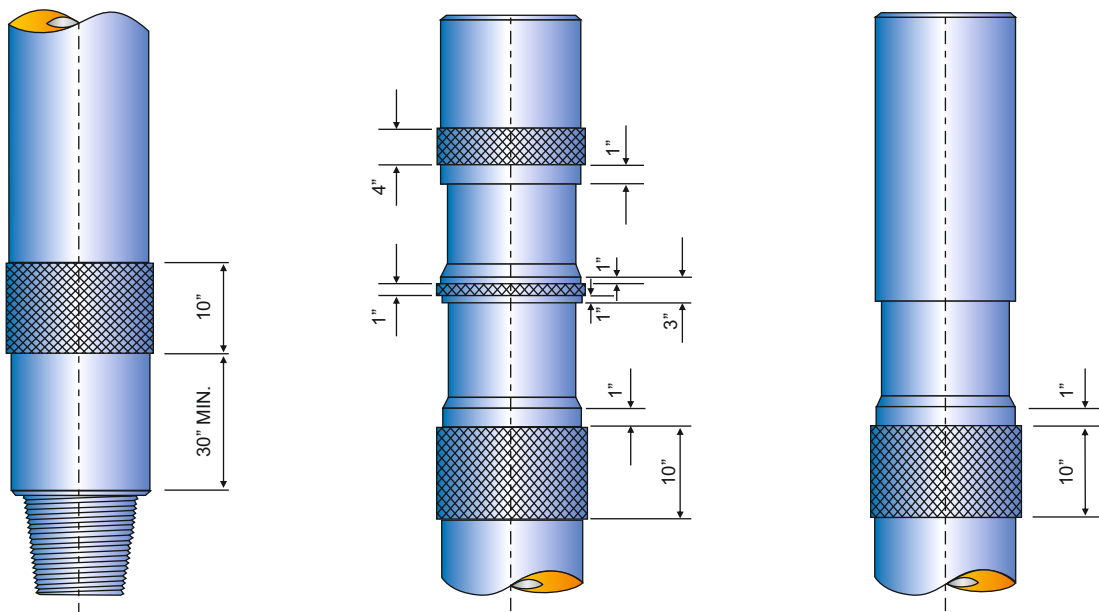

**Type - A**  
**Pin End**

**Type - B**  
**Box End With Zip Lift**  
**(Elevator And Slip Recess)**

**Type - C**  
**(Slip Recess Only)**

(c) Drill Collar Hard Banding

