

LONG SWEEP SWIVEL JOINT (BASIC DIMENSIONS) STYLE-40

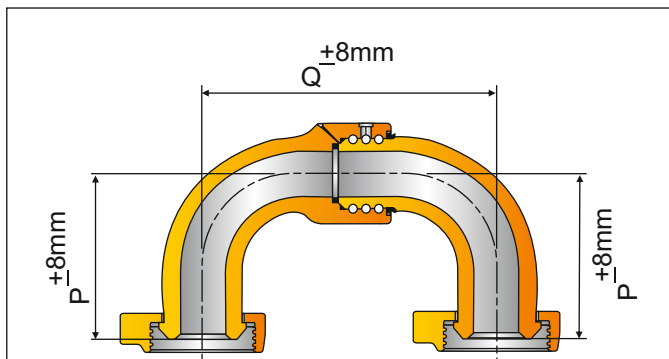

STYLE - 40 LONG SWEEP SWIVEL JOINT
 END CONNECTION = UNION (M X M) FIG.602/1002/1502*
 MODEL:- PLSSJ - 40MM

SIZE	P (MM)	P (INCH)	Q (MM)	Q (INCH)	WT. (LBSF)	WT. (KGF)
1"	115	4.52	188	7.40	19.0	8.4
1 1/2"	151	5.94	239	9.41	57.0	26.0
2"	156	6.14	272	10.70	58.0	26.2
3"	230	9.05	417	16.42	123.0	56.0
4"	310	12.20	539	21.22	273.0	124.0

* FOR 2002 /2202 UNION ENDS CONSULT FACTORY

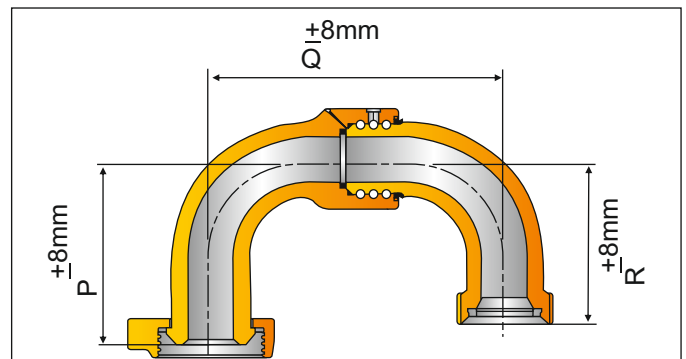

STYLE - 40 LONG SWEEP SWIVEL JOINT
 END CONNECTION = UNION (M X F) FIG.602/1002/1502*
 MODEL:- PLSSJ - 40MF

SIZE	P (MM)	P (INCH)	Q (MM)	Q (INCH)	R (MM)	R (INCH)	WT. (LBSF)	WT. (KGF)
1"	115	4.52	188	7.40	111	4.37	15.0	6.8
1 1/2"	151	5.94	239	9.41	128	5.04	46.3	21.0
2"	156	6.14	272	10.70	145	5.70	47.4	21.5
3"	230	9.05	417	16.42	203	8.00	108.0	49.0
4"	310	12.20	539	21.22	247	9.72	229.0	104.0

* FOR 2002 /2202 UNION ENDS CONSULT FACTORY

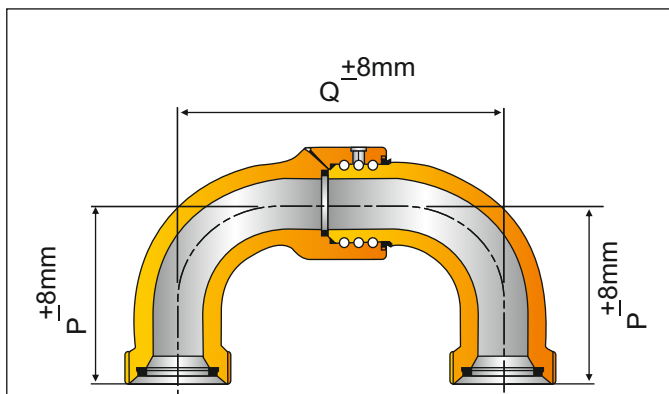

STYLE - 40 LONG SWEEP SWIVEL JOINT
 END CONNECTION = UNION (F X F) FIG.602/1002/1502*
 MODEL:- PLSSJ - 40FF

SIZE	P (MM)	P (INCH)	Q (MM)	Q (INCH)	WT. (LBSF)	WT. (KGF)
1"	111	4.37	188	7.40	11.24	5.1
1 1/2"	128	5.04	239	9.41	37.0	16.7
2"	145	5.70	272	10.70	37.5	17.0
3"	203	8.00	417	16.42	92.5	42.0
4"	247	9.72	539	21.22	183.0	83.0

* FOR 2002 /2202 UNION ENDS CONSULT FACTORY

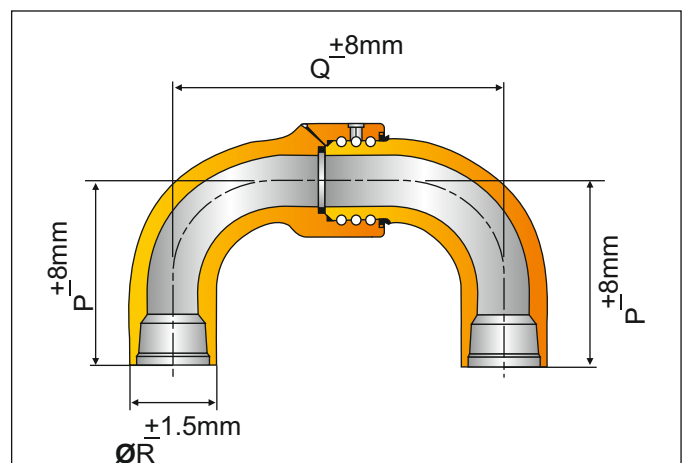

STYLE - 40 LONG SWEEP SWIVEL JOINT
 END CONNECTION = THREADED
 MODEL:- PLSSJ - 40T

SIZE	P (MM)	P (INCH)	Q (MM)	Q (INCH)	R (MM)	R (INCH)	WT. (LBSF)	WT. (KGF)
1"	112	4.41	188	7.40	48.5	1.91	10.0	4.4
1 1/2"	144	5.67	239	9.41	182.0	3.22	37.0	16.7
2"	163	6.42	272	10.70	82.0	3.22	37.5	17.0
3"	239	9.41	417	16.42	108.0	4.25	95.0	43.0
4"	285	11.22	539	21.22	127.0	5.00	196.0	89.0