

SHORT SWEEP SWIVEL JOINT (BASIC DIMENSIONS) STYLE-10

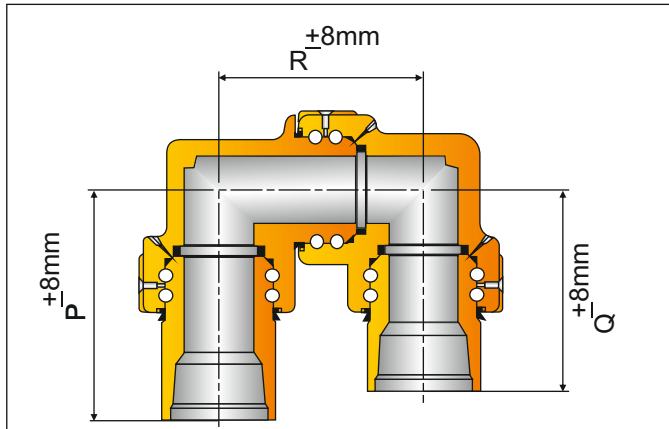

STYLE - 10 SHORT SWEEP SWIVEL JOINT

END CONNECTION = LP THREAD

MODEL:- PSSSJ - 10T

SIZE	P (MM)	P (INCH)	Q (MM)	Q (INCH)	R (MM)	R (INCH)	WT. (LBSF)	WT. (KGF)
1"	118	4.65	118	4.65	108	4.25	11.6	5.25
1 1/2"	136	5.35	121	4.75	110	4.33	15.0	6.70
2"	165	6.49	150	5.90	152	5.98	43.0	19.5
2 1/2"	225	8.85	182	7.16	195	7.67	51.0	23.0
3"	240	9.44	220	8.66	202	7.95	86.0	39.0
4"	275	10.82	252	9.92	260	10.23	126.3	57.3

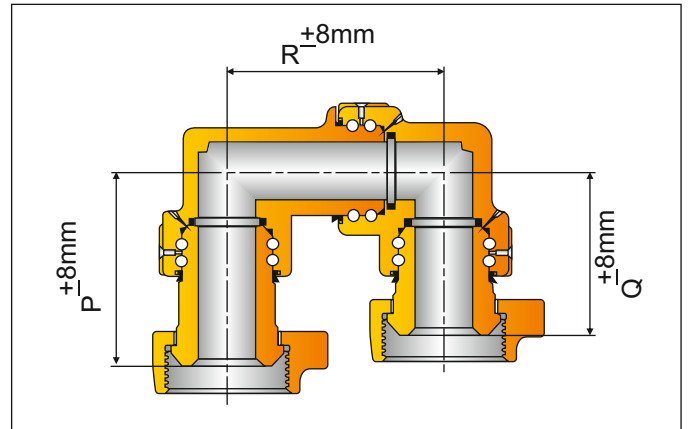

STYLE - 10 SHORT SWEEP SWIVEL JOINT

END CONNECTION = UNION (M X M) FIG.602/1002/1502

MODEL:- PSSSJ - 10MM

SIZE	P (MM)	P (INCH)	Q (MM)	Q (INCH)	R (MM)	R (INCH)	WT. (LBSF)	WT. (KGF)
1"	153	6.02	118	4.65	108	4.25	16.3	7.4
1 1/2"	165	6.50	121	4.75	110	4.33	27.1	12.3
2"	198	7.80	150	5.90	152	5.98	54.0	24.5
2 1/2"	233	9.17	182	7.16	195	7.67	69.0	31.2
3"	271	10.67	220	8.66	202	7.95	112.0	50.65
4"	306	12.05	252	9.92	260	10.23	161.0	73.0

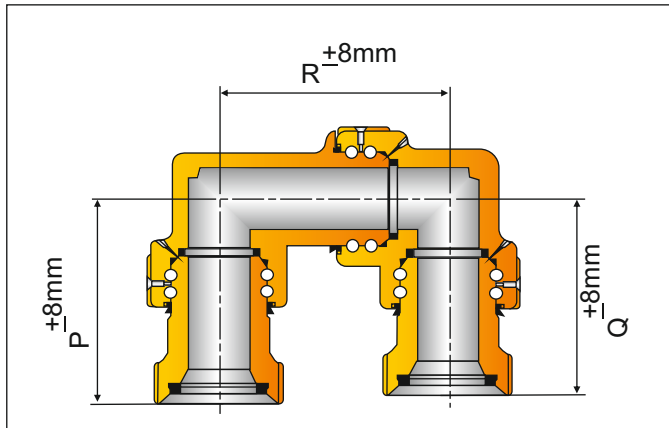

STYLE - 10 SHORT SWEEP SWIVEL JOINT

END CONNECTION = UNION (F X F) FIG.602/1002/1502

MODEL:- PSSSJ - 10FF

SIZE	P (MM)	P (INCH)	Q (MM)	Q (INCH)	R (MM)	R (INCH)	WT. (LBSF)	WT. (KGF)
1"	153	6.02	118	4.65	108	4.25	15.4	7.0
1 1/2"	165	6.50	121	4.75	110	4.33	19.0	8.55
2"	198	7.80	150	5.90	152	5.98	38.1	17.3
2 1/2"	233	9.17	182	7.16	195	7.67	59.0	26.6
3"	271	10.67	220	8.66	202	7.95	100.0	45.3
4"	306	12.05	252	9.92	260	10.23	142.2	64.5

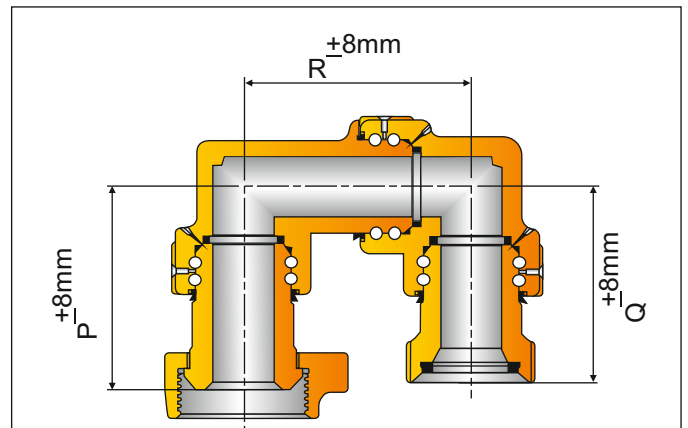

STYLE - 10 SHORT SWEEP SWIVEL JOINT

END CONNECTION = UNION (M X F) FIG.602/1002/1502

MODEL:- PSSSJ - 10MF

SIZE	P (MM)	P (INCH)	Q (MM)	Q (INCH)	R (MM)	R (INCH)	WT. (LBSF)	WT. (KGF)
1"	153	6.02	118	4.65	108	4.25	15.65	7.1
1 1/2"	165	6.50	121	4.75	110	4.33	23.0	10.4
2"	198	7.80	150	5.90	152	5.98	46.3	21.0
2 1/2"	233	9.17	182	7.16	195	7.67	64.0	29.0
3"	271	10.67	220	8.66	202	7.95	106.0	48.0
4"	306	12.05	252	9.92	260	10.23	152.2	69.0